



# T500-1 Series

## Truck Cranes



### FEATURES

**60 ton (54 mt)  
maximum lifting capacity**

**110 ft. (33.5 m)  
maximum boom length**

**170 ft. (51.8 m)  
maximum tip height**

**Four-section full power,  
mechanically synchronized  
boom with single lever control**

**Swingaway jib offsettable  
0°, 15° or 30°**

**Two-speed main and auxiliary  
winches**

**Quick-reeving boom head and  
hook block**

**Fully independent multi-position  
out and down outriggers**

**Environmental operator's cab  
optimized load visibility and  
productivity**

**Electro-Proportional Joystick  
Control**

**RCI 510 load system Rated  
Capacity Indicator**

**Travel speeds to 65 mph  
(105 km/h)**

**Air suspension standard on  
front and rear axles**

**Easy to read load chart books  
include range diagrams**

**12-month or 2000 hours warranty,  
major weldments are  
5-years or 10,000 hours**

**Simple, Available  
and Cost Effective™**

Machines shown may have optional equipment

# TEREX T500-1 SERIES

## Truck Cranes

T560-1 – 60 tons (54 mt)

### 110-ft. (33.5 m) FOUR-SECTION, FULL-POWER, MECHANICALLY SYNCHRONIZED BOOM WITH SINGLE LEVER CONTROL

- High strength, four plate construction welded inside and out with embossed side plate holes to reduce weight and increase strength.
- Single boom hoist cylinder provides boom elevation of -4° to 76° for easier reeving changes and close radius operation.
- Quick-reeving boom head; no need to remove wedge from socket.
- 360° house lock standard.

### ENVIRONMENTAL OPERATOR'S CAB

- Rated Capacity Indicator (RCI) system including anti-two block system with automatic function disconnects.
- Deluxe six-way adjustable operator's seat has torsion bar suspension and adjustable head and arm rests.
- Sound and weather insulated for comfort.
- Removable front window, hinged tinted glass skylight, and sliding right-hand window.
- Armrest mounted dual axis controls for winch(s), swing, and boom elevation; foot control pedals for sing brake, boom telescope, and throttle.
- Complete instrumentation. Environmentally-sealed rocker switches. Circuit breakers cab.

### RUGGED, EASY-TO-MANEUVER CARRIER

- Chassis is Terex designed and built with 8 x 4 drive.
- Full aluminum decking reduces weight.
- Multiple lockable storage compartments and optional ground level outrigger controls are built into decking.
- Eaton/Fuller 10 speed manual transmission standard, Allison 6 speed automatic transmission optional.
- Air suspension standard on front and rear axles
- Full air brakes on all wheels with split circuit system.
- Fully independent hydraulic outriggers may be utilized fully extended to 21 ft. (6.40 m), in their 1/2 extended position, or fully retracted.
- Standard Tier II Detroit Diesel Series 60 engine.
- Tachometer and aluminum rims standard.

### POWERFUL, TWO-SPEED WINCHES

- 533 fpm (162 m/min) maximum line speed, 15,639 lbs. (7093 kg) maximum line pull. Single lever control.
- Integral automatic brake.
- Electronic drum indicators.
- Winch drum rollers, tapered drum flanges.



### HIGH CAPACITY, DEPENDABLE HYDRAULIC SYSTEM

- Three gear pumps driven from engine flywheel housing PTO with manual, or double and single pumps drive by hot-shift PTO's with automatic. Combined system capability is 115 gpm (435 lpm).
- Hydraulic reservoir with 114 gal. (443 l) capacity and full flow oil filtration system.

### OPTIONS INCLUDE:

- 32 ft. or 33 to 57 ft. (9.68 or 10.15 to 17.30m) swing-on jib. both offset 0°, 15° or 30°.
- Auxiliary winch with rope.
- Heater/defroster, air conditioner for operator's cab.
- Air conditioner for carrier cab.
- Heavy 11,500 lbs counterweight package with hydraulic removal system.
- Extra heavy 16,500 lbs counterweight package with hydraulic removal system.
- Cold weather kit for carrier cab.

For more information, product demonstration, or details on purchase, lease and rental plans, please contact your local Terex Cranes Distributor.

We reserve the right to amend these specifications at any time without notice. The only warranty applicable is our standard written warranty applicable to the particular product and sale. We make no other warranty, expressed or implied.



# TEREX

**TEREX Cranes**  
106 12th Street S.E.  
Waverly, IA 50677-9466 USA  
TEL: +1 (319) 352-3920  
FAX: +1 (319) 352-5727  
EMAIL: inquire@terexwaverly.com  
WEB: terex.com



# Range Diagram and Lifting Capacity | T560-1

## 60 TON LIFTING CAPACITY

### RANGE DIAGRAM 35' - 110' BOOM

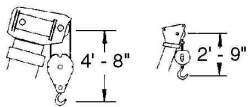

DIMENSIONS ARE FOR LARGEST FACTORY FURNISHED HOOK BLOCK AND HOOK & BALL, WITH ANTI-TWO BLOCK ACTIVATED

COUNTER WEIGHT	W/AUX. WINCH 10,400 LB W/O AUX. WINCH 11,500 LB
BOOM LENGTH	35'-110'
STABILITY PERCENTAGE	ON OUTRIGGERS 85% ON TIRES 75%
PCSA CLASS	10-196

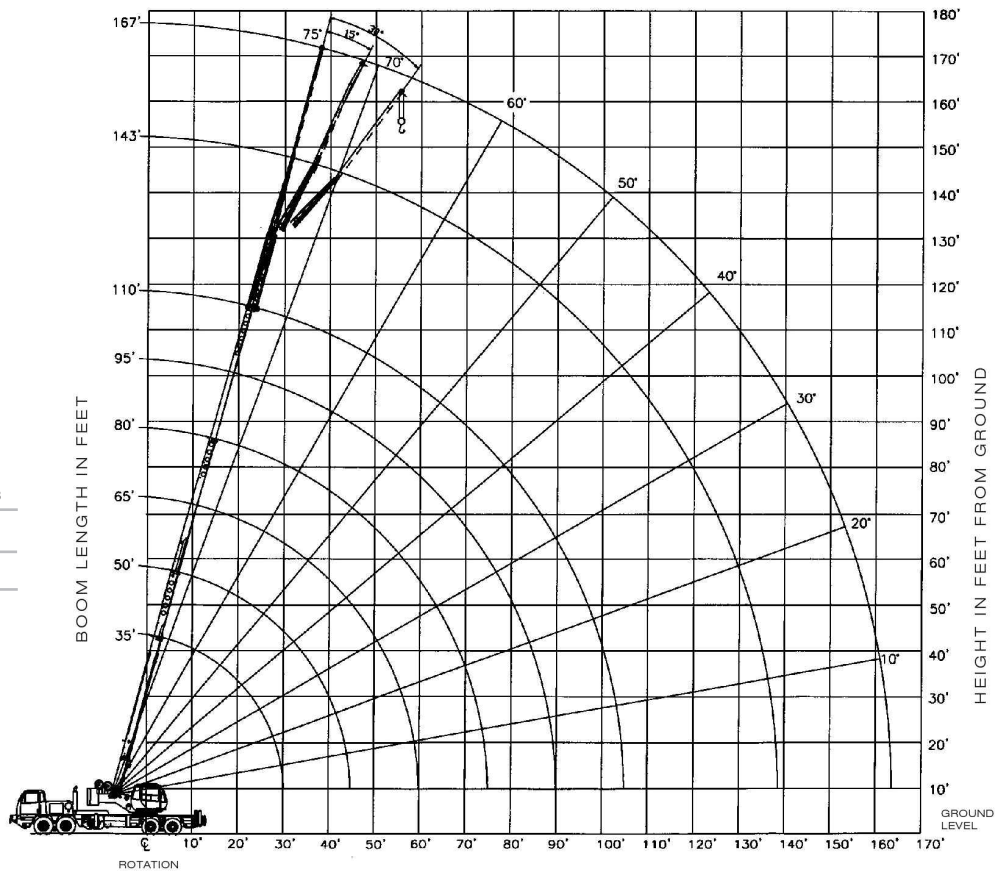

### CRANE WORKING CONDITIONS

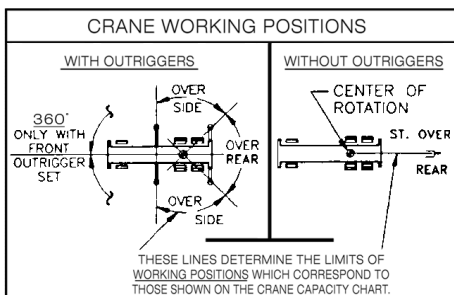

### REDUCTION IN MAIN BOOM CAPACITY

All jib in stowed position	0 lb
Aux. boom in head sheave	100 lb

### HOOK BLOCK WEIGHTS

Hook and ball	239 lb
40T Hook block (4 sheave)	690 lb
50T Hook block (5 sheave)	888 lb
50T Hook block (6 sheave)	913 lb
60T Hook block (5 sheave)	1,151 lb
60T Hook block (6 sheave)	1,151 lb

**LIFTING CAPACITIES** CAUTION: Do not use this specification sheet as a load rating chart. The format of data is not consistent with the machine chart and may be subject to change

**ON OUTRIGGERS - FULLY EXTENDED WITH 16,500 LB COUNTERWEIGHT (OPTIONAL)**

LOAD RADIUS (FT)	BOOM LENGTH 35'			BOOM LENGTH 50'			BOOM LENGTH 65'			LOAD RADIUS (FT)
	LOADED BOOM ANGLE (DEG)	OVER REAR (LB)	360° (LB)	LOADED BOOM ANGLE (DEG)	OVER REAR (LB)	360° (LB)	LOADED BOOM ANGLE (DEG)	OVER REAR (LB)	360° (LB)	
10	66.7	120,000*	120,000*	73.9	80,000*	80,000*				10
12	63.1	107,000*	100,700*	71.5	80,000*	80,000*				12
15	57.5	87,100*	82,800*	67.8	78,400*	78,400*	73.2	61,900*	61,900*	15
20	47.1	62,900*	62,500*	61.5	63,300*	63,300*	68.5	54,800*	54,800*	20
25	34.5	48,300*	48,300*	54.8	49,600*	49,600*	63.7	49,100*	49,100*	25
30	14.8	36,800*	36,700	47.4	39,900*	38,600	58.6	40,500*	39,100	30
31.2	0.0	20,900*	20,900*	39.1	32,800*	29,100	53.3	33,500*	29,700	31.2
40				28.8	27,500*	22,700	47.6	28,300*	23,400	40
45				12.4	22,200*	18,100	41.3	24,200*	19,000	45
46.2				0.0	12,700*	12,700	34.1	20,800*	15,600	46.2
50							34.1	17,900	12,900	50
55							25.2	17,900	12,900	55
60							10.9	14,700	10,700	60
61.2							0.0	8,300*	8,300*	61.2

**USE THESE CHARTS ONLY WHEN ALL OUTRIGGERS ARE FULLY EXTENDED**

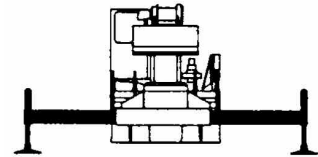

**LIFTING CAPACITIES** CAUTION: Do not use this specification sheet as a load rating chart. The format of data is not consistent with the machine chart and may be subject to change

**ON OUTRIGGERS - FULLY EXTENDED WITH 16,500 LB COUNTERWEIGHT (OPTIONAL)**

LOAD RADIUS (FT)	BOOM LENGTH 80'			BOOM LENGTH 95'			BOOM LENGTH 110'			LOAD RADIUS (FT)
	LOADED BOOM ANGLE (DEG)	OVER REAR (LB)	360° (LB)	LOADED BOOM ANGLE (DEG)	OVER REAR (LB)	360° (LB)	LOADED BOOM ANGLE (DEG)	OVER REAR (LB)	360° (LB)	
10										10
12										12
15										15
20	72.7	46,200*	46,200*							20
25	68.9	40,700*	40,700*	72.3	35,300*	35,300*				25
30	65.0	36,000*	36,000*	69.1	28,000*	26,700*	69.3	24,800*	24,800*	30
35	61.0	32,200*	26,500	65.9	28,000*	28,000*	69.3	24,800*	24,800*	35
40	56.8	28,700*	23,800	62.5	25,200*	24,000	66.5	22,500*	22,500*	40
45	52.4	24,600*	19,300	59.1	23,100*	19,500	63.7	20,600*	19,600	45
50	47.1	21,300*	16,000	55.5	21,300*	16,200	60.7	18,800*	16,300	50
55	42.7	18,400	13,400	51.2	18,600	13,600	57.7	17,400*	13,700	55
60	37.1	15,800	11,300	47.8	16,000	11,500	54.5	16,200	11,700	60
65	30.6	13,600	9,600	43.6	13,900	9,800	51.2	14,100	10,000	65
70	22.7	11,900	8,100	39.0	12,200	8,400	47.8	12,300	8,600	70
75	9.8	10,300	6,800	33.9	10,700	7,200	44.2	10,900	7,400	75
76.2	0.0	5,500*	5,500	28.1	9,400	6,200	40.3	9,600	6,400	76.2
85				20.8	8,200	5,200	36.1	8,500	5,500	85
90				9.0	7,200	4,400	31.5	7,500	4,700	90
91.2				0.0	3,600*	3,600	26.0	6,600	4,000	91.2
100							19.3	5,800	3,300	100
106.2							8.3	5,100	2,700	106.2

**\*\*MAXIMUM CAPACITY AT 0 DEGREE BOOM ANGLE**

BOOM LENGTH 35'			BOOM LENGTH 50'			BOOM LENGTH 65'			BOOM LENGTH 80'			BOOM LENGTH 95'			BOOM LENGTH 110'		
LOAD RADIUS (FT)	OVER FRONT (LB)	360° (LB)	LOAD RADIUS (FT)	OVER FRONT (LB)	360° (LB)	LOAD RADIUS (FT)	OVER FRONT (LB)	360° (LB)	LOAD RADIUS (FT)	OVER FRONT (LB)	360° (LB)	LOAD RADIUS (FT)	OVER FRONT (LB)	360° (LB)	LOAD RADIUS (FT)	OVER FRONT (LB)	360° (LB)
31.2	21,000*	21,000*	46.2	12,800*	12,600*	61.2	8,400*	8,300	76.2	5,600*	5,000	91.2	3,700*	2,900	106.17	2,400*	1,500

**LIFTING CAPACITIES** **CAUTION:** Do not use this specification sheet as a load rating chart. The format of data is not consistent with the machine chart and may be subject to change

**ON OUTRIGGERS - MID POSITION AND WITH 16,500 LB COUNTERWEIGHT (OPTIONAL)**

LOAD RADIUS (FT)	BOOM LENGTH 35'		BOOM LENGTH 50'		BOOM LENGTH 65'		BOOM LENGTH 80'		BOOM LENGTH 95'		BOOM LENGTH 110'		LOAD RADIUS (FT)
	LOADED BOOM ANGLE (DEG)	360° (LB)	LOADED BOOM ANGLE (DEG)	360° (DEG)	LOADED BOOM ANGLE (LB)	360° (DEG)	LOADED BOOM ANGLE (LB)	360° (DEG)	LOADED BOOM ANGLE (LB)	360° (DEG)	LOADED BOOM ANGLE (LB)	360° (DEG)	
10	66.7	105,200*	73.9	80,000*									10
12	63.1	90,000*	71.5	80,000*									12
15	57.4	73,100*	67.8	74,200*	73.2	61,900*							15
20	47.1	41,300	61.5	42,600	68.5	43,200	72.7	43,600					20
25	34.5	27,000	54.8	28,500	63.7	29,000	68.9	29,300	72.7	29,500			25
30	14.8	18,700	47.4	20,400	58.6	21,000	65.0	21,300	69.1	21,500	72.1	21,600	30
31.2	0.0	17,100	39.1	15,200	53.3	15,900	61.0	16,100	65.9	16,300	69.3	16,500	31.2
40			28.8	11,500	47.6	12,200	56.8	12,600	62.5	12,800	66.5	12,900	40
45			12.4	8,700	41.3	9,500	52.4	9,900	59.1	10,100	63.7	10,300	45
46.2			0.0	8,000	34.1	7,400	46.1	7,900	55.5	8,100	60.7	8,200	46.2
55					25.2	5,800	42.7	6,200	51.2	6,500	57.7	6,600	55
60					10.9	4,400	37.1	4,900	47.8	5,200	54.5	5,300	60
61.2					0.0	4,000	30.6	3,800	43.6	4,100	51.2	4,300	61.2
70							22.7	2,800	39.0	3,100	47.8	3,300	70
75							9.8	2,000	33.9	2,300	44.2	2,500	75

**\*\*MAXIMUM CAPACITY AT 0 DEGREE BOOM ANGLE**

BOOM LENGTH 35'		BOOM LENGTH 50'		BOOM LENGTH 65'		BOOM LENGTH 80'		BOOM LENGTH 95'		BOOM LENGTH 110'	
LOAD RADIUS (FT)	360° (LB)	LOAD RADIUS (FT)	360° (LB)	LOAD RADIUS (FT)	360° (LB)	LOAD RADIUS (FT)	360° (LB)	LOAD RADIUS (FT)	360° (LB)	LOAD RADIUS (FT)	360° (LB)
31.2	13,400	46.2	5,900	61.2	2,500						

**USE THESE CHARTS ONLY WHEN ALL OUTRIGGERS ARE PINNED IN MID POSITION**

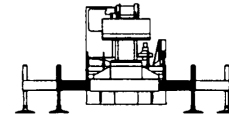

**ON OUTRIGGERS - RETRACTED AND WITH 16,500 LB COUNTERWEIGHT (OPTIONAL)**

LOAD RADIUS (FT)	BOOM LENGTH 35'		BOOM LENGTH 50'		BOOM LENGTH 65'		BOOM LENGTH 80'		BOOM LENGTH 95'		BOOM LENGTH 110'		LOAD RADIUS (FT)
	LOADED BOOM ANGLE (DEG)	360° (LB)	LOADED BOOM ANGLE (DEG)	360° (DEG)	LOADED BOOM ANGLE (LB)	360° (DEG)	LOADED BOOM ANGLE (LB)	360° (DEG)	LOADED BOOM ANGLE (LB)	360° (DEG)	LOADED BOOM ANGLE (LB)	360° (DEG)	
10	66.7	61,700	73.9	60,900									10
12	63.1	44,700	71.5	45,700									12
15	57.4	30,300	67.8	31,500	73.2	32,000							15
20	47.1	18,200	61.5	19,500	68.5	20,000	72.7	20,300					20
25	34.5	11,700	54.8	13,100	63.7	13,700	68.9	13,900	72.3	14,100			25
30	14.8	7,600	47.4	9,000	58.6	9,700	65.0	10,000	69.1	10,200	72.1	10,300	30
31.2	0.0	6,700	39.1	6,300	53.3	7,000	61.0	7,300	65.9	7,500	69.3	7,600	31.2
40			28.8	4,300	47.6	5,000	56.8	5,300	62.5	5,600	66.5	5,700	40
45				2,700	41.3	3,500	52.4	3,800	59.1	4,100	63.7	4,200	45
46.2					2300	2,300	51.2	2,700	55.5	2,900	60.7	3,100	50
55							51.2	2,000	57.7	2,100	57.7	2,100	55

**\*\*MAXIMUM CAPACITY AT 0 DEGREE BOOM ANGLE**

BOOM LENGTH 35'		BOOM LENGTH 50'		BOOM LENGTH 65'		BOOM LENGTH 80'		BOOM LENGTH 95'		BOOM LENGTH 110'	
LOAD RADIUS (FT)	360° (LB)	LOAD RADIUS (FT)	360° (LB)	LOAD RADIUS (FT)	360° (LB)	LOAD RADIUS (FT)	360° (LB)	LOAD RADIUS (FT)	360° (LB)	LOAD RADIUS (FT)	360° (LB)
31.2	4,000										

**USE THESE CHARTS WHEN ALL OUTRIGGER BEAMS ARE NOT IN EITHER THE MID OR FULLY EXTENDED POSITION**

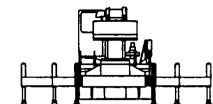

**LIFTING CAPACITIES** CAUTION: Do not use this specification sheet as a load rating chart. The format of data is not consistent with the machine chart and may be subject to change

**ON OUTRIGGERS - FULLY EXTENDED WITH 11,500 LB COUNTERWEIGHT**

LOAD RADIUS (FT)	BOOM LENGTH 35'			BOOM LENGTH 50'			BOOM LENGTH 65'			LOAD RADIUS (FT)
	LOADED BOOM ANGLE (DEG)	OVER REAR (LB)	360° (LB)	LOADED BOOM ANGLE (DEG)	OVER REAR (LB)	360° (LB)	LOADED BOOM ANGLE (DEG)	OVER REAR (LB)	360° (LB)	
10	66.7	120,000*	120,000*	73.9	60,100*	60,100*				10
12	63.1	106,500*	106,500*	71.5	60,100*	60,100*				12
15	57.5	83,400*	83,400*	67.9	60,100*	60,100*	73.2	58,800*	58,800*	15
20	47.1	60,200*	60,200*	61.5	60,100*	60,100*	68.5	52,200*	52,200*	20
25	34.5	46,100*	46,100*	54.8	47,500*	47,500*	63.7	46,900*	46,900*	25
30	14.8	36,600*	32,000	47.4	38,100*	33,900	58.6	38,700*	34,400	30
31.2	0.0	20,900*	20,900*	39.1	31,400	25,600	53.3	32,000	26,200	31.2
40				28.8	26,100	19,600	47.6	26,800	20,300	40
46.2				0.0	12,700*	12,700*	34.1	19,200	13,400	46.2
50							34.1	18,200	13,200	50
55							25.2	15,300	10,800	55
60							10.9	13,000	8,800	60
61.2							0.0	8,300*	8,300*	61.2
70										70
75										75
80										80
85										85
90										90
95										95

**USE THESE CHARTS ONLY WHEN ALL OUTRIGGERS ARE FULLY EXTENDED**

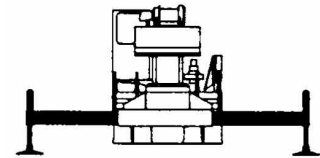

**LIFTING CAPACITIES** CAUTION: Do not use this specification sheet as a load rating chart. The format of data is not consistent with the machine chart and may be subject to change

**ON OUTRIGGERS - FULLY EXTENDED WITH 11,500 LB COUNTERWEIGHT**

LOAD RADIUS (FT)	BOOM LENGTH 80'			BOOM LENGTH 95'			BOOM LENGTH 110'			LOAD RADIUS (FT)
	LOADED BOOM ANGLE (DEG)	OVER REAR (LB)	360° (LB)	LOADED BOOM ANGLE (DEG)	OVER REAR (LB)	360° (LB)	LOADED BOOM ANGLE (DEG)	OVER REAR (LB)	360° (LB)	
10										10
12										12
15										15
20	72.7	46,200*	46,200*							20
25	68.9	40,700*	40,700*	72.3	35,300*	35,300*				25
30	65.0	36,000*	35,100	69.1	31,100*	31,100*	69.3	24,800*	24,800*	30
35	61.0	32,200*	26,500	65.9	28,000*	26,700	69.3	24,800*	24,800*	35
40	56.8	27,400*	20,800	62.5	25,200*	21,000	66.5	22,500*	21,200*	40
45	52.4	23,400*	16,800	59.1	23,100*	17,000	63.7	20,600*	17,100	45
50	47.1	19,600	13,800	55.5	19,800	14,000	60.7	18,800	14,100	50
55	42.7	16,600	11,400	51.2	16,800	11,600	57.7	16,900	11,800	55
60	37.1	14,200	9,500	47.8	14,400	9,800	65.5	14,500	9,900	60
65	30.6	12,200	7,900	43.6	12,400	8,200	51.2	12,600	8,400	65
70	22.7	10,500	6,600	39.0	10,800	6,900	47.8	11,000	7,100	70
75	9.8	9,000	5,400	33.9	9,400	5,800	44.2	9,600	6,000	75
76.2	0.0	5,500*	5,100	28.1	8,200	4,900	40.3	8,400	5,100	76.2
85				20.8	7,100	4,000	36.1	7,400	4,300	85
90				9.0	6,200	3,300	31.5	6,400	3,500	90
91.2				0.0	3,600*	3,100	26.0	5,600	2,900	91.2
100							19.3	4,900	2,300	100
105							8.3	4,200	1,800	105
106.2							0.0	2,300*	1,600	106.2

**\*\*MAXIMUM CAPACITY AT 0 DEGREE BOOM ANGLE**

BOOM LENGTH 35'			BOOM LENGTH 50'			BOOM LENGTH 65'			BOOM LENGTH 80'			BOOM LENGTH 95'			BOOM LENGTH 110'		
LOAD RADIUS (FT)	OVER REAR (LB)	360° (LB)	LOAD RADIUS (FT)	OVER REAR (LB)	360° (LB)	LOAD RADIUS (FT)	OVER REAR (LB)	360° (LB)	LOAD RADIUS (FT)	OVER REAR (LB)	360° (LB)	LOAD RADIUS (FT)	OVER REAR (LB)	360° (LB)	LOAD RADIUS (FT)	OVER REAR (LB)	360° (LB)
31.2	21,000*	21,000*	46.2	12,800*	12,600*	61.2	8,400*	8,300	76.2	5,600*	5,000	91.2	3,700*	2,900	106.17	2,400*	1,500

**LIFTING CAPACITIES** **CAUTION:** Do not use this specification sheet as a load rating chart. The format of data is not consistent with the machine chart and may be subject to change

**ON OUTRIGGERS - MID POSITION AND WITH 11,500 LB COUNTERWEIGHT**

LOAD RADIUS (FT)	BOOM LENGTH 35'		BOOM LENGTH 50'		BOOM LENGTH 65'		BOOM LENGTH 80'		BOOM LENGTH 95'		BOOM LENGTH 110'		LOAD RADIUS (FT)
	LOADED BOOM ANGLE (DEG)	360° (LB)	LOADED BOOM ANGLE (DEG)	360° (LB)	LOADED BOOM ANGLE (DEG)	360° (LB)	LOADED BOOM ANGLE (DEG)	360° (LB)	LOADED BOOM ANGLE (DEG)	360° (LB)	LOADED BOOM ANGLE (DEG)	360° (LB)	
10	66.7	102,700*	73.9	80,000*									10
12	63.1	87,700*	71.5	80,000*									12
15	57.4	63,600	67.8	65,000	73.2	61,900*							15
20	47.1	35,300	61.5	36,600	68.5	37,200	72.7	37,500					20
25	34.5	22,700	65.8	24,200	63.7	24,700	68.9	25,000	72.3	25,200			25
30	14.8	15,400	47.4	17,100	58.3	17,700	65.0	18,000	69.1	18,100	72.1	18,300	30
31.2	0.0	13,900	39.1	12,400	53.3	13,100	61.0	13,400	65.9	13,600	69.3	13,800	31.2
40			28.8	9,200	47.6	10,000	56.8	10,300	62.5	10,500	66.5	10,600	40
45			12.4	6,700	41.3	7,600	52.4	8,000	59.1	8,200	63.7	8,300	45
46.2			0.0	6,100	34.1	5,700	47.1	6,200	55.5	6,400	60.7	6,500	46.2
55					25.2	4,300	42.7	4,700	51.2	5,000	57.7	5,100	55
60					10.9	3,000	37.1	3,500	47.8	3,800	54.5	4,000	60
61.2					0.0	2,700	30.6	2,500	43.6	2,800	51.2	3,000	61.2
70							22.7	1,700	39.0	2,000	47.8	2,200	70

**\*\*MAXIMUM CAPACITY AT 0 DEGREE BOOM ANGLE**

BOOM LENGTH 35'		BOOM LENGTH 50'		BOOM LENGTH 65'		BOOM LENGTH 80'		BOOM LENGTH 95'		BOOM LENGTH 110'	
LOAD RADIUS (FT)	360° (LB)	LOAD RADIUS (FT)	360° (LB)	LOAD RADIUS (FT)	360° (LB)	LOAD RADIUS (FT)	360° (LB)	LOAD RADIUS (FT)	360° (LB)	LOAD RADIUS (FT)	360° (LB)
31.2	13,400	46.2	5,900	61.2	2,500						

**USE THESE CHARTS ONLY WHEN ALL OUTRIGGERS ARE PINNED IN MID POSITION**

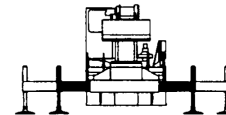

**ON OUTRIGGERS - RETRACTED AND WITH 11,500 LB COUNTERWEIGHT**

LOAD RADIUS (FT)	BOOM LENGTH 35'		BOOM LENGTH 50'		BOOM LENGTH 65'		BOOM LENGTH 80'		BOOM LENGTH 95'		BOOM LENGTH 110'		LOAD RADIUS (FT)
	LOADED BOOM ANGLE (DEG)	360° (LB)	LOADED BOOM ANGLE (DEG)	360° (LB)	LOADED BOOM ANGLE (DEG)	360° (LB)	LOADED BOOM ANGLE (DEG)	360° (LB)	LOADED BOOM ANGLE (DEG)	360° (LB)	LOADED BOOM ANGLE (DEG)	360° (LB)	
10	66.7	53,600	73.9	54,800									10
12	63.1	38,500	71.5	39,600									12
15	57.4	25,800	67.8	27,000	73.2	27,500							15
20	47.1	15,000	61.5	16,400	68.5	16,800	72.7	17,100					20
25	34.5	9,300	54.8	10,600	63.7	11,200	68.9	11,500	72.3	11,700			25
30	14.8	5,600	47.4	7,000	58.6	7,700	65.0	8,000	69.1	8,200	72.1	8,300	30
31.2	0.0	4,800	39.1	4,600	53.3	5,300	61.0	5,600	65.9	5,800	69.3	5,900	31.2
40			28.8	2,800	47.6	3,500	56.8	3,900	62.5	4,100	66.5	4,200	40
45					41.3	2,100	52.4	2,500	59.1	2,800	63.7	2,900	45
50											60.7	1,900	50

**\*\*MAXIMUM CAPACITY AT 0 DEGREE BOOM ANGLE**

BOOM LENGTH 35'		BOOM LENGTH 50'		BOOM LENGTH 65'		BOOM LENGTH 80'		BOOM LENGTH 95'		BOOM LENGTH 110'	
LOAD RADIUS (FT)	360° (LB)	LOAD RADIUS (FT)	360° (LB)	LOAD RADIUS (FT)	360° (LB)	LOAD RADIUS (FT)	360° (LB)	LOAD RADIUS (FT)	360° (LB)	LOAD RADIUS (FT)	360° (LB)
31.2	4,800										

**USE THESE CHARTS WHEN ALL OUTRIGGER BEAMS ARE NOT IN EITHER THE MID OR FULLY EXTENDED POSITION**

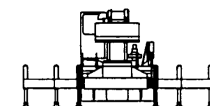

**LIFTING CAPACITIES** **CAUTION:** Do not use this specification sheet as a load rating chart. The format of data is not consistent with the machine chart and may be subject to change

**ON OUTRIGGERS - FULLY EXTENDED WITH 7,500 LB COUNTERWEIGHT**

LOAD RADIUS (FT)	BOOM LENGTH 35'			BOOM LENGTH 50'			BOOM LENGTH 65'			LOAD RADIUS (FT)
	LOADED BOOM ANGLE (DEG)	OVER REAR (LB)	360° (LB)	LOADED BOOM ANGLE (DEG)	OVER REAR (LB)	360° (LB)	LOADED BOOM ANGLE (DEG)	OVER REAR (LB)	360° (LB)	
10	66.7	120,000*	120,000*	73.9	80,000*	80,000*				10
12	63.1	103,400*	69,800*	71.5	80,000*	80,000*				12
15	57.4	71,000*	79,100*	67.8	78,100*	78,400*	73.2	61,900*	61,600*	15
20	46.1	58,300*	58,300*	61.5	59,600*	59,600*	68.5	54,800*	56,800*	20
25	34.5	44,600*	41,600	54.8	45,900*	42,800	63.7	46,600*	46,500	25
30	14.8	35,300*	28,100	47.4	36,800*	29,900	58.6	37,400*	30,500	30
31.2	0.0	20,900*	20,900*	39.1	30,200*	22,200	53.3	30,900*	22,800	31.2
40				28.8	24,700	17,000	47.6	25,400	17,700	40
45				12.4	19,800	13,200	41.3	20,700	14,100	45
46.2				0.0	12,700*	12,300	34.1	17,100	11,300	46.2
55							25.2	14,200	9,100	55
61.2							0.0	8,300*	6,900	61.2

**USE THESE CHARTS ONLY WHEN ALL OUTRIGGERS ARE FULLY EXTENDED**

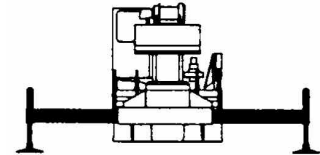

**ON OUTRIGGERS - FULLY EXTENDED WITH 7,500 LB COUNTERWEIGHT**

LOAD RADIUS (FT)	BOOM LENGTH 80'			BOOM LENGTH 95'			BOOM LENGTH 110'			LOAD RADIUS (FT)
	LOADED BOOM ANGLE (DEG)	OVER REAR (LB)	360° (LB)	LOADED BOOM ANGLE (DEG)	OVER REAR (LB)	360° (LB)	LOADED BOOM ANGLE (DEG)	OVER REAR (LB)	360° (LB)	
10										10
12										12
15										15
20	72.2	46,200*	46,200*							20
25	68.9	40,700*	40,700*	72.3	35,300*	35,300*				25
30	65.0	36,000*	30,800	69.1	31,100*	31,100	72.1	27,500*	27,500*	30
35	61.0	31,300*	23,100	65.9	28,000*	23,300	69.3	24,800*	23,500	35
40	56.8	25,700	18,000	62.5	25,200*	18,200	66.5	22,500*	18,400	40
45	52.4	21,000	14,400	59.1	21,200	14,600	63.7	20,600*	14,700	45
50	47.1	17,500	11,700	55.5	17,700	11,900	60.7	17,800	12,000	50
55	42.7	14,700	6,900	51.2	14,900	9,800	57.7	15,000	9,900	55
60	37.1	12,500	7,900	47.8	12,700	8,100	54.5	12,800	8,200	60
65	30.6	10,600	6,400	43.6	10,900	6,700	51.2	11,000	6,800	65
70	22.7	9,100	5,200	39.0	9,400	5,500	47.8	6,500	5,700	70
75	9.8	7,700	4,200	33.9	8,100	4,500	44.2	8,300	4,700	75
76.2	0.0	5,500	3,900	28.1	7,000	3,700	40.3	7,200	3,900	76.2
85				20.8	6,000	2,900	36.1	6,200	3,200	85
90				9.0	5,100	2,200	31.5	5,400	2,500	90
91.2				0.0	3,600	2,000	26.0	4,600	1,900	91.2
100							19.3	3,900	1,400	100
106.2							0.0	2,300	700	106.2

**\*\*MAXIMUM CAPACITY AT 0 DEGREE BOOM ANGLE**

BOOM LENGTH 35'			BOOM LENGTH 50'			BOOM LENGTH 65'			BOOM LENGTH 80'			BOOM LENGTH 95'			BOOM LENGTH 110'		
LOAD RADIUS (FT)	OVER REAR (LB)	360° (LB)	LOAD RADIUS (FT)	OVER REAR (LB)	360° (LB)	LOAD RADIUS (FT)	OVER REAR (LB)	360° (LB)	LOAD RADIUS (FT)	OVER REAR (LB)	360° (LB)	LOAD RADIUS (FT)	OVER REAR (LB)	360° (LB)	LOAD RADIUS (FT)	OVER REAR (LB)	360° (LB)
31.2	21,000*	21,000*	46.2	12,800*	12,500	61.2	8,400*	6,900	76.2	5,600*	3,900	91.2	3,700*	2,000	106.17	2,400*	700



**LIFTING CAPACITIES** **CAUTION:** Do not use this specification sheet as a load rating chart. The format of data is not consistent with the machine chart and may be subject to change

**ON OUTRIGGERS - FULLY EXTENDED WITH 4,500 LB COUNTERWEIGHT**

LOAD RADIUS (FT)	BOOM LENGTH 35'			BOOM LENGTH 50'			BOOM LENGTH 65'			LOAD RADIUS (FT)
	LOADED BOOM ANGLE (DEG)	OVER REAR (LB)	360° (LB)	LOADED BOOM ANGLE (DEG)	OVER REAR (LB)	360° (LB)	LOADED BOOM ANGLE (DEG)	OVER REAR (LB)	360° (LB)	
10	66.7	120,000*	120,000*	73.9	80,000*	80,000*				10
12	63.1	100,900*	95,000*	71.5	80,000*	80,000*				12
15	57.4	78,900*	77,600*	67.8	78,400*	78,400*	73.2	61,900*	61,900*	15
20	47.1	56,800*	56,800*	61.5	58,100*	58,100*	68.5	54,800*	54,800*	20
25	34.5	43,400*	38,700	54.8	44,700*	40,200	63.7	45,300*	40,900	25
30	14.8	34,200*	26,100	47.4	35,700*	27,900	58.6	36,400*	28,500	30
31.2	0.0	20,900*	20,900	39.1	29,300*	20,600	53.3	29,900*	21,200	31.2
40				28.8	22,900	15,600	47.6	23,700	16,300	40
45				12.4	18,300	12,000	41.3	19,200	12,900	45
46.2				0.0	12,700	11,100	34.1	15,800	10,200	46.2
55							25.2	13,100	8,100	55
60							10.9	10,900	6,400	60
61.2							0.0	8,300	6,000	61.2

**USE THESE CHARTS ONLY WHEN ALL OUTRIGGERS ARE FULLY EXTENDED**

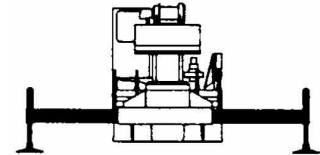

**ON OUTRIGGERS - FULLY EXTENDED WITH 4,500 LB COUNTERWEIGHT**

LOAD RADIUS (FT)	BOOM LENGTH 80'			BOOM LENGTH 95'			BOOM LENGTH 110'			LOAD RADIUS (FT)
	LOADED BOOM ANGLE (DEG)	OVER REAR (LB)	360° (LB)	LOADED BOOM ANGLE (DEG)	OVER REAR (LB)	360° (LB)	LOADED BOOM ANGLE (DEG)	OVER REAR (LB)	360° (LB)	
10										10
12										12
15										15
20	72.2	46,200*	46,200*							20
25	68.9	40,700*	40,700*	72.3	35,300*	35,300*				25
30	65.0	36,000*	28,800	69.1	31,100*	29,000	72.1	27,500*	27,500*	30
35	61.0	30,200	21,500	65.9	28,000*	21,700	69.3	24,800*	21,800	35
40	56.8	24,000	16,600	62.5	24,200	16,800	66.5	22,500*	17,000	40
45	52.4	19,500	13,200	59.1	19,700	13,400	63.7	19,800	13,500	45
50	47.1	16,200	10,600	55.5	16,400	10,800	60.7	16,500	10,900	50
55	42.7	13,600	8,600	51.2	13,800	8,800	57.7	13,900	8,900	55
60	37.1	11,500	7,000	47.8	11,700	7,200	54.5	11,800	7,300	60
65	30.6	9,700	5,600	43.6	10,000	5,900	51.2	10,100	6,000	65
70	22.7	8,200	4,400	39.0	8,600	4,800	47.8	8,700	4,900	70
75	9.8	6,900	3,400	33.9	7,300	3,800	44.2	7,500	4,000	75
76.2	0.0	5,500	3,200	28.1	6,300	3,000	43.3	6,500	3,200	76.2
85				20.8	5,300	2,300	36.1	5,600	2,500	85
90				9.0	4,500	1,600	31.5	4,800	1,900	90
91.2				0.0	3,600	1,400	26.0	4,000	400	91.2
100							19.3	3,400	800	100
105							8.3	2,800		105
106.2							0.0	2,300*		106.2

**\*\*MAXIMUM CAPACITY AT 0 DEGREE BOOM ANGLE**

BOOM LENGTH 35'			BOOM LENGTH 50'			BOOM LENGTH 65'			BOOM LENGTH 80'			BOOM LENGTH 95'			BOOM LENGTH 110'		
LOAD RADIUS (FT)	OVER REAR (LB)	360° (LB)	LOAD RADIUS (FT)	OVER REAR (LB)	360° (LB)	LOAD RADIUS (FT)	OVER REAR (LB)	360° (LB)	LOAD RADIUS (FT)	OVER REAR (LB)	360° (LB)	LOAD RADIUS (FT)	OVER REAR (LB)	360° (LB)	LOAD RADIUS (FT)	OVER REAR (LB)	360° (LB)
31.2	20,900*	20,900*	46.2	12,700*	10,800	61.2	8,300*	5,800	76.2	5,600*	3,100	91.2	3,700*	1,400	106.17	2,300*	



**LIFTING CAPACITIES** **CAUTION:** Do not use this specification sheet as a load rating chart. The format of data is not consistent with the machine chart and may be subject to change

**SIDE STOW JIB ON FULLY EXTENDED OUTRIGGERS WITH 16,500 LB COUNTERWEIGHT (OPTIONAL)**

LOADED BOOM ANGLE (DEG)	57' OFFSETTABLE JIB									33' OFFSETTABLE JIB									LOADED BOOM ANGLE (DEG)
	0° OFFSET			15° OFFSET			30° OFFSET			0° OFFSET			15° OFFSET			30° OFFSET			
	LOAD RADIUS (REF) (FT)	REAR ONLY (LB)	360° (LB)	LOAD RADIUS (REF) (FT)	REAR ONLY (LB)	360° (LB)	LOAD RADIUS (REF) (FT)	REAR ONLY (LB)	360° (LB)	LOAD RADIUS (REF) (FT)	REAR ONLY (LB)	360° (LB)	LOAD RADIUS (REF) (FT)	REAR ONLY (LB)	360° (LB)	LOAD RADIUS (REF) (FT)	REAR ONLY (LB)	360° (LB)	
75	48	6,500*	6,500*	63	4,500*	4,500*	73	3,300	3,300*	37	12,500*	12,500*	48	8,500*	8,500*	54	6,400	6,400	75
73	54	6,400*	6,400*	69	4,300*	4,300*	78	3,200	3,200*	43	11,800*	11,800*	53	8,100*	8,100*	59	6,200	6,200	73
71	60	6,200*	6,200*	74	4,100*	4,100*	83	3,100	3,100*	48	11,200*	11,200*	58	7,800*	7,800*	63	6,100	6,100	71
68	69	6,000*	6,000*	82	3,900*	3,900*	90	3,000	3,000*	56	10,300*	10,300*	65	7,500*	7,500*	70	5,900	5,900	68
65	78	5,400*	5,400*	90	3,700*	3,700*	97	2,900	2,900*	64	9,500*	9,500*	72	7,100*	7,100*	76	5,900	5,900	65
62	86	4,900*	4,900*	97	3,500*	3,500*	103	2,800	2,800*	71	8,800*	8,700	78	6,700*	6,700*	82	5,600	5,600	62
59	94	4,500*	4,500*	104	3,300*	3,300*	109	2,700	2,700*	78	8,200*	7,400	74	6,400*	6,400*	88	5,400	5,400	59
55	103	4,200*	4,200*	112	3,100*	3,100*	117	2,600	2,600*	86	7,600*	4,900	92	6,200*	5,400	950	5,300	5,100	55
51	112	3,800*	3,700	120	2,900*	2,900*	124	2,500	2,500*	940	7,100*	4,800	99	5,900*	4,400	102	8,500	4,200	51
47	120	3,500*	3,000	127	2,800*	2,700	130	2,500	2,500*	101	6,100	3,800	106	5,600*	3,600	108	5,100	3,500	47
43	128	3,300*	2,400	134	2,700*	2,200	136	2,400	2,100	108	5,300	3,100	112	5,000	2,900	114	4,900	2,900	43
38	136	6,100*	1,800	141	2,600*	1,700	1420	2,400	1,600	115	4,400	2,400	118	4,300	2,200	120	4,200	2,200	38
32	145	2,800*	1,300	148	2,500*	1,100	149	2,400	1,200	123	3,600	1,700	125	3,500	1,600	126	3,500	1,600	32
25	153	2,300	700	155	1,300					130	3,000	1,000	131	2,900	900				25
17	159	1,900		160	1,900					136	2,500			2,400					17
0	164	300								139	400								0

**Notes For Jib Capacities:**

- A. For all boom lengths less than the maximum with a jib erected, the rated loads are determined by boom angle only in the appropriate column.
- B. For boom angle not shown, use the capacity of the next lower boom angle.
- C. Listed radii are for extended main boom only.

**ON TIRES - WITH 16,500 LB COUNTERWEIGHT (OPTIONAL)**

RADIUS (FT)	MAX BOOM LENGTH (FT)	ALL		
		STATIONARY		PICK & CARRY
		STATIC	CREEP	2.5 MPH
		STRAIGHT OVER FRONT		
10	35	26,800*	16,400*	10,300*
12	35	24,300*	14,600*	8,900*
15	35	21,100*	12,300*	7,200*
20	25	17,000*	9,300*	4,900*
25	50	13,800*	7,000*	3,100*
30	50	11,100*	5,100*	
35	50	9,200*	3,700*	
40	65	7,800*	2,800*	
45	65	6,700*	2,100*	
50	65	5,700*		
55	65	4,800*		
60	80	3,800		
65	80	3,000		
70	95	2,300		
75	95	1,800		

**Notes For On Tire Capacities:**

- A. For Pick and Carry operations, boom must be centered over the front of the crane with swing brake and lock engaged. Use minimum boom point height and keep load close to ground surface.
- B. The load should be restrained from swinging. NO ON TIRE OPERATION WITH JIB ERECTED.
- C. Without outriggers, never maneuver the boom beyond listed load radii for applicable tires to ensure stability.
- D. Creep speed is crane movement of less than 200' (61 m) in a 30 minute period and not exceeding 1.0 mph (1.6 km/h).
- E. Refer to General Notes for additional information.

**MAXIMUM PERMISSIBLE HOIST LINE LOAD**

LINE PARTS	1	2	3	4	5	6	7	8	9	10	11*
MAIN & AUX. HOIST	11,250	22,500	33,750	45,000	56,250	67,500	78,750	90,000	101,250	112,500	123,750
WIRE ROPE: 5/8" ROTATION RESISTANT COMPACTED STRAND, 34 X 7, GRADE 2160, MINIMUM BREAKING STRENGTH - 28.21 TONS.											
5/8" 6 X 19 OR 6 X 37 XIPS, IWRC, PREFORMED RIGHT REGULAR LAY MINIMUM BREAKING STRENGTH - 20.6 TONS.											
* IF SIX SHEAVES ARE NOT INSTALLED IN THE BOOM HEAD, THE FIRST PART OF LINE MAY BE ROUTED OVER THE AUXILIARY BOOM HEAD SHEAVE. THIS REEVING MAY ONLY BE USED AT MINIMUM RATED RADIUS. DO NOT PULL THE HOOK BLOCK CLOSER THAN 10 FT. FROM THE BOOM HEAD WITH A LOAD ON THE HOOK BLOCK!											



# TRUCK CRANE T560-1

**LIFTING CAPACITIES** **CAUTION:** Do not use this specification sheet as a load rating chart. The format of data is not consistent with the machine chart and may be subject to change.

## SIDE STOW JIB ON FULLY EXTENDED OUTRIGGERS WITH 11,500 LB COUNTERWEIGHT

LOADED BOOM ANGLE (DEG)	33' OFFSETTABLE JIB									57' OFFSETTABLE JIB									LOADED BOOM ANGLE (DEG)
	0° OFFSET			15° OFFSET			30° OFFSET			0° OFFSET			15° OFFSET			30° OFFSET			
	LOAD RADIUS (REF) (FT)	REAR ONLY (LB)	360° (LB)	LOAD RADIUS (REF) (FT)	REAR ONLY (LB)	360° (LB)	LOAD RADIUS (REF) (FT)	REAR ONLY (LB)	360° (LB)	LOAD RADIUS (REF) (FT)	REAR ONLY (LB)	360° (LB)	LOAD RADIUS (REF) (FT)	REAR ONLY (LB)	360° (LB)	LOAD RADIUS (REF) (FT)	REAR ONLY (LB)	360° (LB)	
75	39	12,500*	12,500*	48	8,500*	8,500*	54	6,400*	6,400*	47	6,500*	6,500*	64	4,500*	4,500*	73	3,300*	3,300*	75
73	44	11,800*	11,800*	53	8,100*	8,100*	59	6,200*	6,200*	54	6,400*	6,400*	69	4,300*	4,300*	78	3,200*	3,200*	73
71	49	11,200*	11,200*	58	7,800*	7,800*	63	6,100*	6,100*	60	6,200*	6,200*	75	4,100*	4,100*	83	3,100*	3,100*	71
68	57	10,300*	10,300*	65	7,500*	7,500*	70	5,900*	5,900*	69	6,000*	6,000*	83	3,900*	3,900*	90	3,000*	3,000*	68
65	64	9,500*	9,000*	71	7,100*	7,100*	77	5,900*	5,900*	78	5,400*	5,400*	90	3,700*	3,700*	97	2,900*	2,900*	65
62	71	8,800*	7,500*	78	6,700*	6,500*	83	5,600*	5,600*	86	4,900*	4,900*	97	3,500*	3,500*	103	2,800*	2,800*	62
59	78	8,200*	6,300*	84	6,400*	5,500*	88	5,400*	5,200*	64	4,500*	4,500*	104	3,300*	3,300*	109	2,700*	2,700*	59
55	86	7,500*	4,900*	62	6,200*	4,400*	96	5,300*	4,200*	104	4,200*	3,600*	113	3,100*	3,100*	117	2,600*	2,600*	55
51	94	6,400*	3,700*	99	5,900*	3,500*	102	5,200*	3,300*	113	3,800*	2,800*	120	2,900*	2,600*	124	2,500*	2,400*	51
47	101	4,500*	2,900*	105	5,100*	2,800*	108	4,800*	2,600*	121	3,500*	2,100*	128	2,800*	2,000*	130	2,500*	1,900*	47
43	107	4,600*	2,200*	111	4,400*	2,100*	114	4,400*	2,000*	128	3,200*	1,600*	134	2,700*	1,500*	136	2,400*	1,400*	43
38	114	3,700*	1,600*	118	3,600*	1,500*	119	3,400*	1,400*	136	2,800*	1,100*	141	2,600*	1,000*	142	2,400*	900*	38
32	122	2,900*	900*	125	2,900*	900*	125	2,700*	800*	144	2,300*		148	2,200*		149	2,100*		32
25	129	2,300*		131	2,300*					152	1,800*		155	1,800*					25
17	135	1,900*		136	1,800*					159	1,400*		160	1,400*					17
0	141	400*																	

**Notes For Jib Capacities:**

- A. For all boom lengths less than the maximum with a jib erected, the rated loads are determined by boom angle only in the appropriate column.
- B. For boom angle not shown, use the capacity of the next lower boom angle.
- C. Listed radii are for extended main boom only.

## ON TIRES - WITH 11,500 LB COUNTERWEIGHT

RADIUS (FT)	MAX BOOM LENGTH (FT)	ALL		
		STATIONARY		PICK & CARRY
		STATIC	CREEP	2.5 MPH
10	35	28,100*	17,700*	11,600*
12	35	25,500*	15,800*	10,200*
15	35	22,300*	13,400	8,300*
20	50	18,000*	10,300	5,800*
25	50	14,600*	7,600	3,900*
30	50	11,900*	5,800	2,300*
35	50	9,600	4,400	1,200*
40	65	7,200	3,500	
45	65	5,700	2,700	
50	65	4,600	2,000	
55	65	3,600	1,400	
60	80	2,800		
65	80	1,500		
70	95	1,200		

**Notes For Tire Capacities:**

- A. For Pick and Carry operations, boom must be centered over the front of the crane with swing brake and lock engaged. Use minimum boom point height and keep load close to ground surface.
- B. The load should be restrained from swinging. NO ON TIRE OPERATION WITH JIB ERECTED.
- C. Without outriggers, never maneuver the boom beyond listed load radii for applicable tires to ensure stability.
- D. Creep speed is crane movement of less than 200' (61 m) in a 30 minute period and not exceeding 1.0 mph (1.6 km/h).
- E. Refer to General Notes for additional information.

## MAXIMUM PERMISSIBLE HOIST LINE LOAD

LINE PARTS	1	2	3	4	5	6	7	8	9	10	11*
MAIN & AUX. HOIST	11,250	22,500	33,750	45,000	56,250	67,500	78,750	90,000	101,250	112,500	123,750

WIRE ROPE: 5/8" ROTATION RESISTANT COMPACTED STRAND, 34 X 7, GRADE 2160, MINIMUM BREAKING STRENGTH - 28.21 TONS.

5/8" 6 X 19 OR 6 X 37 XIPS, IWRC, PREFORMED RIGHT REGULAR LAY MINIMUM BREAKING STRENGTH - 20.6 TONS.

\* IF SIX SHEAVES ARE NOT INSTALLED IN THE BOOM HEAD, THE FIRST PART OF LINE MAY BE ROUTED OVER THE AUXILIARY BOOM HEAD SHEAVE. THIS REEVING MAY ONLY BE USED AT MINIMUM RATED RADIUS. DO NOT PULL THE HOOK BLOCK CLOSER THAN 10 FT. FROM THE BOOM HEAD WITH A LOAD ON THE HOOK BLOCK!







# TEREX®

## General Notes | T500-1 Series

### GENERAL

1. Rated loads as shown on Lift Charts pertain to this machine as originally manufactured and equipped. Modifications to the machine or use of optional equipment or other than that specified can result in a reduction of capacity.
2. Construction equipment can be hazardous if improperly operated or maintained. Operation and maintenance of this machine shall be in compliance with the information in the Operator's, Parts and Safety Manuals supplied with this machine. If These manuals are missing, order replacements from the manufacturer through your distributor.
3. These warnings to not constitute all of the operating conditions for the crane. The operator and job site supervision must read the OPERATORS MANUAL, CIMA SAFETY MANUAL, APPLICABLE OSHA REGULATIONS, AND SOCIETY OF MECHANICAL ENGINEERS (ASME) SAFETY STANDINGS FOR CRANES.
4. This crane and its load ratings are in accordance with POWER CRANE & SHOVEL ASSOCIATION, STANDARD NO. 4 SAE CRANE LOAD STABILITY TEST CODE J765A, SAE METHOD OF TEST FOR CRANE STRUCTURE J1063 AND APPLICABLE SAFETY CODE FOR CRANES, DERRICKS AND HOISTS, ASME/ANSI B30.5

### DEFINITIONS

1. **LOAD RADIUS** - The horizontal distance from the axis of rotation before loading to the center of the vertical hoist line or tackle with a load applied.
2. **LOADED BOOM ANGLE** - It is the angle between the boom base section and the horizontal, after lifting the rated load at the rated radius. the boom angle before loading should be greater to account for deflections. The loaded boom angle combined with boom length give only an approximation of the operating radius.
3. **WORKING AREA** - Areas measured in a circular arc about the centerline of rotation as shown in the diagram.
4. **FREELY SUSPENDED LOAD** - Load hanging free with no direct external force applied except by the hoist rope.
5. **SIDE LOAD** - Horizontal force applied to the lifted load either on the ground or in the air.
6. **NO LOAD STABILITY LIMIT** - The stability limit radius shown on the range diagrams is the radius beyond which it is not permitted to position the boom, when the boom angle is less than the minimum shown on the applicable load chart, because the machine can overturn without any load.
7. **BOOM SIDE OF CRANE** - The side of the crane over which the boom is positioned when in OVER SIDE working position.

### SET-UP

1. Crane load ratings are based on the crane being leveled and standing on a firm, uniform supporting surface.
2. Crane load ratings on outriggers are based on all outrigger beams being fully extended or in the case of partial extension ratings mechanically pinned in the appropriate position, and the tires free of the supporting surface.
3. Crane load ratings on tires depend on appropriate inflation pressure and the tire conditions. Caution must be exercised when increasing air pressures in tires. Consult Operator's Manual for precautions.
4. Use of jibs, lattice-type boom extensions, or fourth section pullouts extended is not permitted for pick and carry operations.
5. Consult appropriate section of the Operator's and Service Manual for more exact description of hoist line reeving.
6. The use of more parts of line than required by the load may result in having insufficient rope to allow the hook block to reach the ground.
7. Properly maintained wire rope is essential for safe crane operation. Consult Operator's Manual for proper maintenance and inspection requirements.
8. When spin-resistant wire rope is used, the allowable rope loading shall be the breaking strength divided by five (5), unless otherwise specified by the wire rope manufacturer.
9. Do not elevate the boom above 60° unless the boom is positioned in-line with the crane's chassis or the outrigger are extended. Failure to observe this warning may result in loss of stability.

### OPERATION

1. **CRANE LOAD RATINGS MUST NOT BE EXCEEDED. DO NOT ATTEMPT TO TIP THE CRANE TO DETERMINE ALLOWABLE LOADS.**
2. When either radius or boom length, or both, are between listed values, the smaller of the two listed load ratings shall be used.
3. Do not operate at longer radii than those listed on the applicable load rating chart (cross hatched areas shown on range diagrams.)
4. The boom angles shown on the Capacity Chart give an approximation of the operating radius for a specified boom length. The boom angle, before loading, should be greater to account for boom deflection. It may be necessary to retract the boom if maximum boom angle is insufficient to maintain rated radius.
5. Power telescoping boom sections must be extended equally.
6. Rated loads include the weight of hook block, slings, and auxiliary lifting devices. Their weights shall be subtracted from the listed rated load to obtain the net load that can be lifted. When lifting over the jib the weight of any hook block, slings, and auxiliary lifting devices at the boom head must be added to the load. When jibs are erected but unused add two (2) times the weight of any hook block, slings, and auxiliary lifting devices at the jib head to the load.
7. Rated loads do not exceed 85% on outriggers or 75% on tires, of the tipping load as determined by SAE Crane Stability Test Code J765a. Structural strength ratings in chart are indicated with an asterisk (\*).
8. Rated loads are based on freely suspended loads. No attempt shall be made to drag a load horizontally on the ground in any direction.
9. The user shall operate at reduced ratings to allow for adverse job conditions, such as: soft or uneven ground, out of level conditions, high winds, side loads, pendulum action, jerking or sudden stopping of loads, hazardous conditions, experience of personnel, two machine lifts, traveling with loads, electric wires, etc. (side pull on boom or jib is hazardous). Derating of the cranes lifting capacity is required when wind speed exceeds 20 MPH. The center of the lifted load must never be allowed to move more than 3° off the center line of the base boom section due to the effects of wind, inertia, or any combination of the two.  
\*Use 2' off the center line of the base boom for a two section boom, 3' for a three section boom, or 4' for a four section boom.
10. The maximum load which can be telescoped is not definable, because of variations in loadings and crane maintenance, but it is permissible to attempt retraction and extension if load ratings are not exceeded.
11. Load ratings are dependent upon the crane being maintained according to manufacturer's specifications.
12. It is recommended that load handling devices, including hooks, and hook blocks, be kept away from boom head at all times.
13. **FOR TRUCK CRANES ONLY:** 360° capacities apply only to machines equipped with a front outrigger jack and all five(5) outrigger jacks properly set. If the front (5th) outrigger jack is not properly set, the work area is restricted to the over side and over rear areas as shown on the Crane Working Positions diagram. Use the 360° load ratings in the overside work areas.
14. Do not lift with outrigger beams positioned between the fully extended and intermediate (pinned) positions.
15. Truck Cranes not equipped with equalizing (bogie) beams between the rear axles may not be used for lifting "on tires". Truck Cranes equipped with equalizing beams and rear air suspension should "dump" the air before lifting "on tires".

### CLAMSHELL, MAGNET, AND CONCRETE BUCKET SERVICE

1. Maximum boom length for clamshell and magnet service is 50'.
2. Weight of clamshell or magnet, plus contents are not to exceed 6,000 lb or 90% of rated lifting capacities, whichever is less. For concrete bucket operation, weight of bucket and load must not exceed 90% of rated lifting capacity.

### TEREX Cranes

106-12th Street S.E.  
Waverly, Iowa 50677-9466 USA

TEL (319) 352-3920 FAX (319) 352-5727

EMAIL [inquire@terexwaverly.com](mailto:inquire@terexwaverly.com)

WEB [terex-cranes.com](http://terex-cranes.com)

**Disclaimer: Effective Date: March, 2008.** Product specifications and prices are subject to change without notice or obligation. The photographs and/or drawings in this document are for illustrative purposes only. Refer to the appropriate Operator's Manual for instructions on the proper use of this equipment. Failure to follow the appropriate Operator's Manual when using our equipment or to otherwise act irresponsibly may result in serious injury or death. The only warranty applicable to our equipment is the standard written warranty applicable to the particular product and sale and Terex makes no other warranty, express or implied. Products and services listed may be trademarks, service marks or trade-names of Terex Corporation and/or its subsidiaries in the USA and other countries.

All rights are reserved. Terex® is a registered trademark of Terex Corporation in the USA and many other countries.  
Copyright 2008 Terex Corporation.

PRINTED IN U.S.

March 2, 2009  
P/N: T5601RDCC



# T500-1 SERIES

truck cranes  
specifications

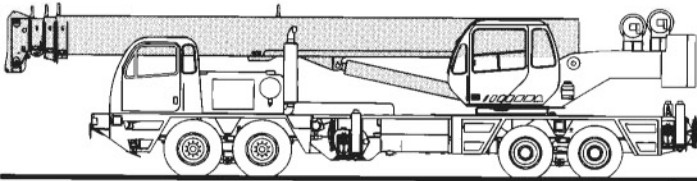

---

## STANDARD BOOM EQUIPMENT

### BOOM

35-110 ft. (10.67-33.53 m), four section full power, mechanically synchronized boom. High-strength four plate construction with embossed side plate holes to reduce weight and increase strength. Anti-friction slide pads. A single boom hoist cylinder provides for boom elevation of -4 to 76 degrees. Maximum tip height is 114 ft. (30.17 m).

### BOOM HEAD

Welded to outer section of boom. Four or five load sheaves and two idler sheaves mounted on heavy duty, anti-friction bearings. Quick reeving boom head. Provisions made for side-stow jib mounting.

---

## OPTIONAL BOOM EQUIPMENT

### JIBS

32 ft. (9.75 m) side stow swing-on one-piece lattice type jib. Single sheave mounted on anti-friction bearing. Jib is offsettable at 0°, 15°, or 30°. Maximum tip height is 145 ft. (44.22 m) with 110 ft. (33.53 m) boom.

33-57 ft. (10.16-17.37 m) side stow swing-on lattice type jib. Single sheave mounted on anti-friction bearing. Jib is extendible to 57 ft. (17.37 m) by means of a 24 ft. (7.62 m) manual pull-out tip section, roller supported for ease of extension. Jib is offsettable at 0°, 15°, or 30°. Maximum tip height is 169 ft. (51.62 m) with 110 ft. (33.53 m) boom.

### AUXILIARY BOOM HEAD

Removable auxiliary boom head has single sheave mounted on anti-friction bearing. Removable pin-type rope guard for quick reeving. Installs on main boom peak only. Removal is not required for jib use.

### HOOK BLOCK

Three, or four nylon sheaves on anti-friction bearings with hook and heavy duty hook latch. Quick reeving design does not require removal of wedge and socket from rope.

### HOOK & BALL

7 ton (6.3 mt) top swivel ball with hook and hook latch.

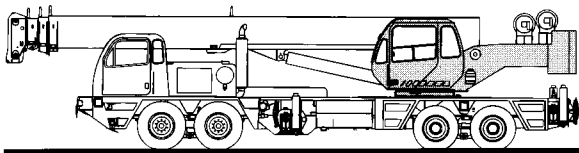

## STANDARD UPPERSTRUCTURE EQUIPMENT

### UPPERSTRUCTURE FRAME

All welded one-piece structure fabricated with high tensile strength alloy steel.

### COUNTERWEIGHT

Integral counterweight removal system permits counterweight to be carried on the deck of the carrier to optimize axle weights and multiple counterweight combinations to be utilized.

### TURNTABLE CONNECTION

Swing bearing is a single row, ball type, with internal teeth. The swing bearing is bolted to the revolving upperstructure and to the carrier frame.

### SWING

A hydraulic motor drives a double planetary reduction gear for precise and smooth swing function. Swing speed (no load) is 2.8 rpm.

### SWING BRAKE

Heavy duty multiple disc swing brake is mechanically actuated from operator's cab by foot pedal. Brake may be locked on or used as a momentary brake.

### RATED CAPACITY INDICATOR

Rated Capacity Indicator with visual and audible warning system and automatic function disconnects. Pictographic display includes: boom radius, boom angle, boom length, allowable load, actual load, and percentage of allowable load registered by bar graph. Operator settable alarms provided for swing angle, boom length, boom angle, tip height, and work area exclusion zone. Anti-two block system includes audio/visual warning and automatic function disconnects.

### OPERATOR'S CAB

Environmental cab with all steel construction, optimum visibility, tinted safety glass throughout, and rubber floor matting is mounted on vibration absorbing pads. The cab has a sliding door on the left side, framed sliding window on the right side, hinged tinted all glass skylight

and removable front windshield to provide optimized visibility of the load open or closed. Acoustical foam padding insulates against sound and weather. Hot air defroster keeps windshield clear. The deluxe six-way adjustable operator's seat is equipped with a torsion bar suspension and includes head and arm rests.

### CONTROLS

Armrest mounted dual axis controls for winch(s), swing, and boom elevation. Winch rotation indication incorporated into control handles. Armrest swings up to improve access and egress. Vernier adjustable hand throttle included. Switches include ignition, engine stop, lights, horn, windshield wipers, defroster, outriggers, 360° house lock, etc. Horn and winch speed shift switches are mounted in the levers. Foot control pedals include swing brake, boom telescope, and throttle.

### INSTRUMENTATION AND ACCESSORIES

In-cab gauges include bubble level, engine oil pressure, fuel, engine temperature, voltmeter. Indicators include high coolant temperature/low engine oil pressure audio visual warning, low coolant level audio visual warning, and Rated Capacity Indicator. Accessories include fire extinguisher, windshield washer/wiper, skylight wiper, left & right hand rear view mirrors, dash and dome lights, and seat belt. Circuit breakers protect electrical circuits.

### HYDRAULIC CONTROL VALVES

Valves are mounted on the rear of the upperstructure and are easily accessible. Valves utilize electric over hydraulic operators and include one pressure compensated load sensing two spool valve for boom elevation and telescope, one pressure compensated load sensing two spool valve for main and auxiliary winch, and one single spool valve for swing. System provides for simultaneous operation of all crane functions. High pressure regeneration feature provides 2-speed boom extension. Quick disconnects are provided for ease of installation of pressure check gauges.

### OPTIONAL EQUIPMENT

Auxiliary Winch • LP Heater/Defroster • Hydraulically Powered Air conditioner • Diesel Heater/Defroster • Tachometer • Work Lights • Heavy Counterweight Package w/Hydraulic Removal System • Extra Heavy Counterweight Package w/Hydraulic Removal System • Digital AM/FM Cassette Radio

## STANDARD CARRIER EQUIPMENT

### CARRIER CHASSIS

Chassis is Terex designed and built with an 8 x 4 drive. Triple box construction frame with internal diaphragms is fabricated from high strength alloy steel and provides superior frame rigidity. Full aluminum decking improves access and reduces weight. Multiple lockable storage compartments and ground level outrigger controls are built into decking. Aluminum engine housing with sliding cover optimizes engine access while reducing weight and improving corrosion resistance. Mud flaps.

### AXLES AND SUSPENSION

Rear Axles - 43,000 lb. (19,504 kg) capacity tandem axles with heat treated housings have inter-axle differential with lockout. Axles are mounted on standard air suspension system over equalizer beams with shock absorbers to distribute weight evenly.  
Front Axles - 46,000 lb (0,865 kg) capacity tubular beam type axles are mounted on standard air suspension system over equalizer beams with shock absorbers.

### TIRES

Front: Four 425/65R22.5-18 P.R. All-position type tubeless.  
Rear: Eight 11R22.5-14P.R. deep tread drive axle type tubeless

### BRAKES

Full air brakes on all wheels with ABS split circuit system  
Front brakes: 16.5 x 6 in. (419 x 152 mm)  
Rear brakes: 16.5 x 7 in. (419 x 178 mm)  
All brakes are air operated "S" cam type with automatic slack adjusters.

Lining areas are 768 in<sup>2</sup> (4954 cm<sup>2</sup>) front and 920 in<sup>2</sup> (5935 cm<sup>2</sup>) rear. Air compressor has standard air dryer. Rear tandem axles have spring-set,

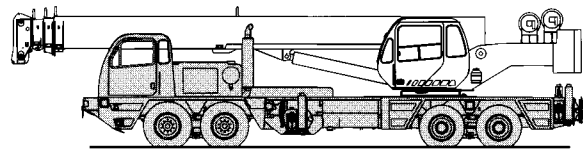

air-released parking or emergency brake chambers. Parking brake is applied with valve mounted on dash panel. Emergency brakes apply automatically when air pressure drops below 60 psi (4.2 kg/cm<sup>2</sup>).

### STEERING

Mechanism includes rack and pinion with integral hydraulic power.

Turning radius: To  $\phi$  of tires  
33'-4" (10.16 m)

### TRANSMISSION

Standard: Eaton/Fuller 10 speed manual transmission.  
Optional: Allison 4500RDS automatic transmission has 6 speeds forward and 1 reverse, with neutral safety start. Provides wide ratio coverage with "hands free" shifting. A lock up torque converter further improves performance.

### MULTI-POSITION & DOWN OUTRIGGERS

Fully independent hydraulic outriggers may be utilized fully extended to 21 ft. (6.40 m), in their 1/2 extended position, or fully retracted. Removable aluminum outrigger pads are 452 in<sup>2</sup> (2919 cm<sup>2</sup>) and stow on the carrier frame. Complete controls and sight leveling bubble are located in the operator's cab. Additional optional ground level controls are incorporated into the aluminum decking. Includes 5th, front outrigger which incorporates a self stowing permanently attached float



## STANDARD CARRIER EQUIPMENT (continued)

### CARRIER CAB

One-man aluminum cab is mounted on vibration absorbing pads and has optimum visibility, safety glass, acoustical foam padding inside cab for insulating against sound and weather, hot air defroster, six-way adjustable torsion bar suspension seat with seat belt and lockable door with roll down window.

### CONTROLS

Included are transmission shift, inter-axled differential lock, cruise control, parking brake, two-speed windshield wiper/washer, heater and defroster, lights, headlight dimmer, dome light, and ignition switch.

### INSTRUMENTS

Included are speedometer, hour meter, tachometer, voltmeter, fuel gauge, engine oil pressure gauge, water temperature gauge, dual air pressure gauges. Warning lights include low coolant level, parking brakes on, low air, pumps engaged, and high beam lights.

### ACCESSORIES

Included are fire extinguisher, right hand and left hand rear view mirrors, electric horn, access steps and grab handles (located at four separate locations around the crane), back-up alarm, two position boom rack, front and rear towing loops.

### LIGHTS

Light package includes headlights with foot operated dimmer switch, clearance lights, tail lights, directional signal lights, four-way hazard flasher lights, back-up lights with audible alarm.

### OPTIONAL EQUIPMENT

Spare Tire with Wheel • Immersion Heater(s) • Pintle Hook • Cold Weather Kit • Series 60 Detroit Diesel Engine w/Allison 4500RDS Automatic Transmission and Jacobs Brake • Air Conditioner • Ground Level Outrigger Controls • Digital AM/FM Cassette Radio

## HYDRAULIC SYSTEM

### HYDRAULIC PUMPS

Triple pump driven from engine flywheel housing PTO with air shifted mechanical pump disconnect at 1.3 times engine speed, w/manual or double and single pumps driven by hot-shift PTO's w/automatic. A separate steering pump is driven directly from the engine. Combined system capacity is 127.4 (482.31 lpm). Hydraulic oil cooler is standard.

#### Main and Auxiliary Winch Pump

60.3 gpm (228.3 lpm) @ 3,500 psi (246.1 kg/cm<sup>2</sup>)

#### Boom Hoist and Telescope Pump

45.1 gpm (170.71 lpm) @ 3,500 psi (246.1 kg/cm<sup>2</sup>)

#### Outrigger and Swing Pump

22 gpm (83.2 lpm) @ 2,500 psi (175 kg/cm<sup>2</sup>)

### Power Steering Pump

8 gpm (30.3 lpm) @ 1500 psi (105.5 kg/cm<sup>2</sup>)

### FILTRATION

Full flow oil filtration system with bypass protection includes a removable 60 mesh (250 micron) suction screen-type filter and 5 micron replaceable return line filter.

### HYDRAULIC RESERVOIR

All welded construction with internal baffles and diffuser. Provides easy access to filters and is equipped with an external sight level gauge. The hydraulic tank is pressurized to aid in keeping out contaminants and in reducing potential pump cavitation. Capacity is 117 gal (443 liters).

## MAIN WINCH SPECIFICATIONS

Hydraulic winch with bent axis piston motor and planetary reduction gearing provides 2-speed operation with equal speeds for power up and down. Winch is equipped with an integral automatic brake, grooved drum, tapered flanges, standard cable roller on drum, and electronic drum rotation indicator.

### PERFORMANCE

Max. line speed (no load)

	LO-RANGE	HI-RANGE
First layer	184 fpm (56.1 m/min)	369 fpm (112.5 m/min)
Fifth layer	266 fpm (81.1 m/min)	533 fpm (162.5 m/min)

Max. line pull-first layer	15,639 lbs (7093 kg)	7,298 lbs (3310 kg)
Max. line pull-fifth layer	10,827 lbs (4911 kg)	5,052 lbs (2291 kg)
Permissible line pull	11,250 lbs (5,103 kg)	

### DRUM DIMENSIONS

10.62 in (270 mm) drum diameter  
 22.42 in (570 mm) length  
 20.0 in (508 mm) flange dia.  
 Cable: 5/8 in. x 500 ft (16 mm x 152.4 m)  
 Cable type: 5/8 in. (16 mm) 6x19 IWRC IPS right regular lay, preformed  
 Min. breaking strength 20.6 tons (18.7 mt).

### DRUM CAPACITY

Max. Storage: 939 ft (286.2 m)  
 7th layer not a working layer  
 Max. Useable: 772 ft (235.3 m)\*  
 \* Based on min. flange height above top layer to comply with ANSI B30.5

## OPTIONAL AUXILIARY WINCH

Hydraulic 2-speed winch with bent axis piston motor, equal speed power up and down, planetary reduction with integral automatic brake, grooved drum with tapered flanges, drum roller, and rotation indicator.

### PERFORMANCE

Max. line speed (no load)

Fifth layer	533 fpm (162.5 m/min)
Max. line pull	
First layer	15,639 lbs. (7093 kg)

### DRUM DIMENSIONS AND CAPACITY

(Same as main winch)

## OPTIONAL HOIST LINE

### MAIN WINCH AND OPTIONAL AUXILIARY WINCH

5/8 in. (16mm) rotation resistant compacted strand 34x7. Min breaking strength 28.21 tons (25.59 mt).

## ENGINE SPECIFICATIONS

Make and Model	Detroit Diesel Series 60
Type	6 Cylinder
Bore and Stroke	5.12 x 6.30 in. (130 x 160 mm)
Displacement	778 cu. in. (12.7 L)
Max. Gross Horsepower	430 hp (320 kw) @ 2100 rpm
Max. Gross Torque@rpm	1450 lb • ft. (1966 N•m)@1200 rpm
Max. Net Horsepower	392 hp (292 kw) @ 1600 rpm
Aspiration	Turbocharged & Aftercooled
Electrical System	12 volt
Alternator	130 amp
Battery @ 0°F	(3) 12V-950 C.C.A
Fuel Capacity	100 gal (379 l)
(Includes standard engine controlled ether starting aid, and Jacobs Brake	

## SPEED AND GRADEABILITY

ENGINE TRANSMISSION	SPEED RANGE	GRADEABILITY
60 Series Manual	65 mph (105 km/h)	100+%
60 Series Allison	65 mph (105 km/h)	100+%

Performance data is based on a gross vehicle weight of 75,000 lbs. (34 014 kg). Performance may vary due to engine performance, weight, tire size, etc. Gradeability data is theoretical and is limited by tire slip, stability, oil pan angle, etc.

# GENERAL DIMENSIONS

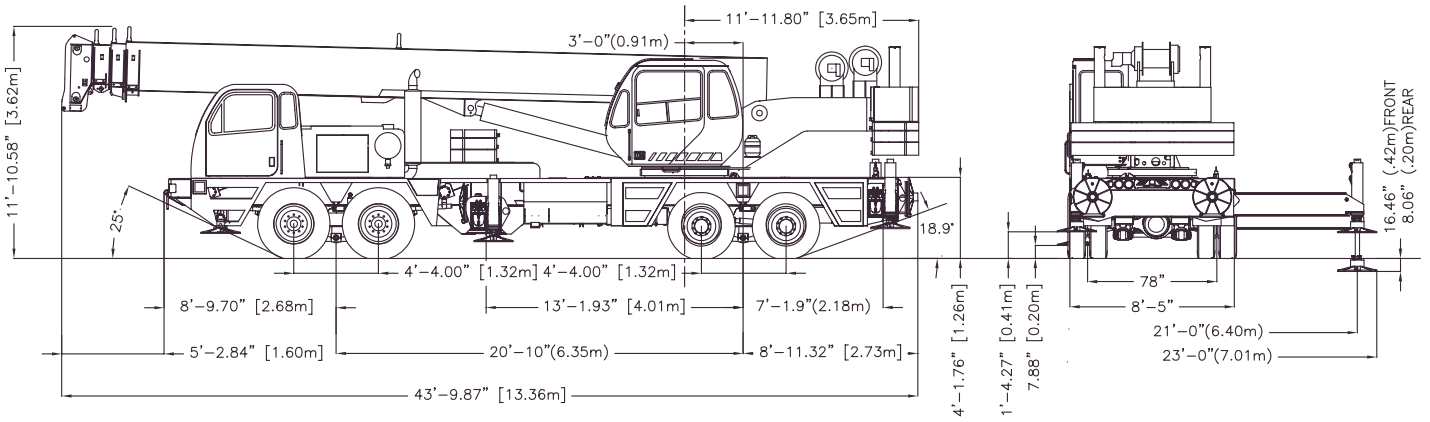

WEIGHTS & AXLE LOADS	GROSS WEIGHT LBS.	UPPER IN TRAVEL POSITION		GROSS WEIGHT LBS.	UPPER IN TRAVEL POSITION	
		FRONT	REAR		FRONT	REAR
<b>Basic Crane with 60 Series Engine, 110'(33.52m) Boom, 360° Mechanical House Lock, 4,500 lb (2,041 kg) Cwt, 1/4 tank of fuel, 425/65R22.5 Load Range L Front &amp; 11R22.5 Load Range G with Alluminum Disc Wheels, and 200 lb. Operator in Cab</b>	<b>72281</b>	<b>33168</b>	<b>39112</b>	<b>32785</b>	<b>15181</b>	<b>17741</b>
<b>Add options</b>						
32' (9.68) Swing-on jib	1270	1194	76	583	548	35
33'-57' (10.7m-17.37m) Swing on jib	2170	1922	248	996	882	114
Auxiliary Boom Head	100	168	-68	46	77	-31
3,000 lb Counterweight Slab on Superstructure	3000	-1102	4102	1360	-500	1860
4,000 lb Counterweight Slab on Superstructure	4000	-1470	5470	1814	-667	2481
5,000 lb Counterweight Slab on Superstructure	5000	-1837	6837	2267	-833	3101
3,000 lb Counterweight Slab on Crane Deck	3000	1974	1026	1360	895	465
4,000 lb Counterweight Slab on Crane Deck	4000	2633	1367	1814	1194	620
5,000 lb Counterweight Slab on Crane Deck	5000	3291	1709	2267	1493	775
Full Tank of Fuel	545	244	301	250	112	138
Aux Winch with Drum Roller and Wire Rope	87	51	36	40	23	17
Heater/Defroster (Upper)	60	4	56	28	2	26
Work Lights	35	8	27	16	4	12
Pintle Hook (Rear)	100	-30	130	46	-14	60
Electric Remote Control	200	100	100	92	46	46
60 Ton (45.3. Mt) Quick Reeving Hook Block (Tied to Bumper - 5 Sheave)	1157	1839	-688	531	844	-316
40 Ton (36.7 mt) Quick Reeving Hook Block (Tied To Bumper - 4 Sheave)	690	1104	-412	317	507	-189
7 Ton (6.3 mt) Hook and Ball (Tied to Bumper)	340	383	143	156	176	66
Spin Resistant Wire Rope (Main Winch)	90	-19	109	41	-9	50
Spin Resistant Wire Rope (Aux Winch)	90	-27	117	41	-12	54
Air Conditioning (Lower Cab)	100	112	-12	46	51	-6
Air Conditioning (Upper Cab)	150	-8	158	69	-4	73

**Note:** weights are for factory supplied equipment and subject to 2% variation due to manufacturing tolerances

WE RESERVE THE RIGHT TO AMEND THESE SPECIFICATIONS AT ANYTIME WITHOUT NOTICE. THE ONLY WARRANTY APPLICABLE IS OUT STANDARD WRITTEN WARRANTY APPLICABLE TO THE PARTICULAR PRODUCT AND SALE. WE MAKE NO OTHER WARRANTY. EXPRESSED OR IMPLIED.



## TEREX

TEREX Cranes  
 106 12th Street S.E.  
 Waverly, IA 50677-9466 USA  
 TEL: +1 (319) 352-3920  
 FAX: +1 (319) 352-5727  
 EMAIL: inquire@terexwaverly.com  
 WEB: terex.com