



**QUICK ATTACH ALUMINUM
PLATFORM WITH LANYARD
INTERLOCK**

**PROVIDING CLASS-LEADING
SAFETY SOLUTIONS FOR ALTEC
DUAL RATED PRODUCTS**

ALL ALUMINUM 2-MAN PLATFORM

The new 2-Man Platform for Altec Dual Rated Products features an all-aluminum construction to help save weight and prevent corrosion. This new platform maintains the traditional capacity of 1,200 lb when used on the AC40E and AC65E and 800 lb when used on the AC45E.

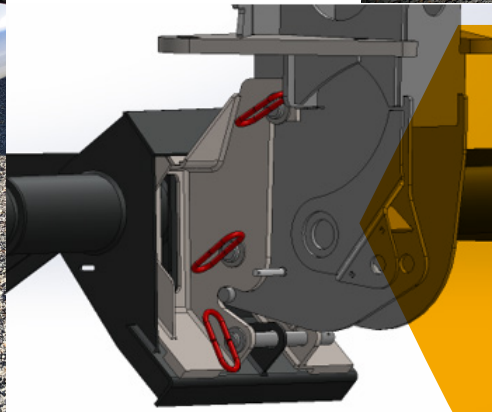

PLATFORM QUICK ATTACH SYSTEM

All Altec Dual Rated Products feature the improved quick attach system for pinning on the platform onto the boom tip or jib tip. This system features a single pin that is installed for secondary retention to further increase the strength of the system and aid in quick installation.

INTEGRATED KICK-STAND

To further improve jobsite safety and aid in simple installation, the new quick attach system features an integrated kick-stand built into the platform yoke. The kick stand is easily deployed to not only balance the platform before attaching it to the boom, but also to place the yoke at the ideal height for quickly lining it up with the boom tip.



OPTIONAL LANYARD INTERLOCK

All platforms on Altec Dual Rated Products have the ability to be upfitted with the optional Lanyard Interlock System. This system takes dual rated product safety to the next level by sensing whether or not the operator has their lanyard attached to the platform. If the operator is not tied off, the system will alarm and prevent operation from the platform.